

Biochrom Asys Atlantis Microplate Washer

User's Manual



Table of Contents

1	Introduction	4
2	Warnings and Hazards	5
2.1.1	Safety symbols	6
3	Precautions.....	8
3.1	Cleaning the instrument.....	8
4	Specifications.....	9
4.1	Metrological specification	9
4.1.1	Rated operating conditions	9
4.1.1	Limits of error and tolerance limits	9
4.2	General technical data	9
4.2.1	Dimensions	9
4.2.2	Power supply	10
4.2.3	Interfacing	10
4.2.4	Options	10
4.3	Cleaning	10
4.4	General features	11
4.5	Standard delivery content	12
4.6	Warnings and directions	13
4.7	Unpacking Procedure	14
4.8	Installation requirements, Environmental operating conditions	14
4.9	Instrument installation procedure.....	15
4.10	Re-packing to prevent damage during transport	17
5	Theory of Operation	18
5.1	Introduction	18
5.2	Main components.....	18
5.3	Hydraulic system	18
5.3.1	Dispensing system	18
5.3.2	Aspirating system	18
6	Warranty	20
6.1	Liability	20
7	Software Principle	21
7.1	Software Navigation.....	21
7.2	Programming Sequence.....	22
7.3	Menus.....	24
7.3.1	Run Procedure	25
7.3.2	Prime / Rinse	26
7.3.3	Define Procedure	27
7.3.4	Define Cycle.....	28
7.3.5	Define Plate	29
7.3.6	Setup	30
7.3.7	Service	31

7.4	Description of the key functions	32
8	Start-up and system setup	33
8.1	Start-Up	33
8.2	Control of the system setup	34
9	Programming	35
9.1	Run Procedure	35
9.2	Prime/Rinse Menu	37
9.2.1	Manual Prime/Rinse	37
9.2.2	Automatic Prime/Rinse	38
9.2.3	Periodic Prime/Rinse	39
9.3	Define Procedure Menu	41
9.4	Define Cycle Menu	46
9.5	Define Plate Menu	50
9.6	Setup Menu	61
9.7	Service Menu	65
10	ERROR MESSAGES	66
10.1.1	Duplicate Name	66
10.1.2	Wrong Manifold	66
10.1.3	No Cycle Defined	66
10.1.4	No Plate Defined	67
10.1.5	Waste Full	67
10.1.6	Liquid Empty	68
10.1.7	Stop Pressed	68
10.1.8	Plate Transport Error	68
10.1.9	Manifold Transport Error	69
11	Maintenance	70
11.1	Recommended regular inspection	70
11.2	Approved parts	70
11.3	Exchanging a Fuse	70
11.4	Cleaning the instrument	71
11.5	Disinfection Procedure	71
12	Intended Use	73
12.1	Quality control	73



1 Introduction

The **Atlantis** is a fully automated, programmable 96-well microplate washer with an 8-way manifold. An optional 16-channel manifold allows washing of 384-well microplates.

The **Atlantis** is designed around your application. It incorporates state of the art technology and software both necessary to allow optimum performance and easy use.

Easy operation is possible through the menu structure of the on-board software. The display and the keyboard provides clear access to all features of the flexible software

The **Atlantis** can be operated with up to 3 different wash liquids selected via the software.

Easy plate setup procedure is provided to optimize the movement of the plate and the manifold according to the different dimensions of different plate types.



2 Warnings and Hazards

➤ **General:**

- If inflammable, toxic or biologically hazardous substances are used when operating the equipment; please observe the instructions and precautions enclosed with such substance.
- Never spill fluids in or on the equipment.
- Wash your hands thoroughly after handling test fluids.
- If equipment has been in contact with hazardous substances, it must be disinfected prior to shipment in accordance with the effective provisions.
- Do not touch the plate during movement of the plate transport (risk of injury).
- The equipment may not be opened other than as described in chapter **11 Maintenance**, since it contains live parts (danger of life).

➤ **Electrical:**

- Voltages dangerous to human life are present in this device. Before removing any covers disconnect the device from the power source.
- Ensure that the power cord supplied with the unit is used.
- The power cord may only be inserted in a socket outlet provided with a protective ground (earth) contact. The protective action must not be negated by use of an extension cord without a protective grounding contact.
- Do not replace fuses without first removing the main power cord.
- Ensure that only fuses with the required rated current and of the specified type are used for replacement. The use of makeshift fuses and the short-circuiting of fuse-holders are prohibited.
- When the apparatus is connected to the main power source, the opening of the covers or removal of components is likely to expose live parts. The device shall be disconnected from all voltage sources before it is opened for adjustment or repair.
- Any adjustment or repair of the opened apparatus under voltage should be avoided, but, if necessary, it must be carried out by qualified service personnel who are aware of the hazards involved.

➤ **Magnetic:**

- The removable plate carriage of this instrument has a very strong permanent magnet mounted. Be sure to never bring any other magnets or Ferro-magnetic parts near to the magnet of the plate carriage (risk of injury).
- Never place credit cards or IDs or any other items using magnet-code (floppy disks, audio- or video tapes,) near to the magnet of the plate carriage (risk of data loss).
- Be careful when placing the plate carriage onto other sensitive medical devices, which may be influenced by magnetic fields.

2.1.1 Safety symbols

The following safety symbols may be found in several locations on the instrument. Only persons who fully understand the safety precautions and recognize shock hazards should operate this instrument.



Alternating current



Protective ground terminal



ON



OFF



Caution, see enclosed document



The symbol on the product indicates that this product shall not be treated as household waste. Instead it shall be handed over to the applicable collection point for the recycling of electrical and electronic equipment.



3 Precautions

3.1 Cleaning the instrument

This instrument is a precision instrument and it requires regular cleaning to ensure the continued precision.

➤ **Liquid Spills**

If any liquid is spilled on the instrument, it should be IMMEDIATELY removed so that the liquid does not attack the surface of the housing.

➤ **Regular cleaning**

The housing of the instrument should be cleaned regularly with a mild household cleaning agent.

Warning: Do not use aggressive solutions!

The area surrounding the plate carrier should be cleaned with a dry cloth.

➤ **Fittings and tubing**

The usual wash buffer tends to crystallize easily on air and can then block tubing and fittings. Use the automatic rinse program daily and do not leave the tubing filled with wash buffer for an extended period of time.

4 Specifications

4.1 Metrological specification

4.1.1 Rated operating conditions

- Warming-up time: Ready for operation immediately after switching-on.
- Operating voltage: 100V - 240V,
180V – 250V autosensing
- Fuses (user exchangeable): 2 pcs. 2.5A, TH 250VAC
Built in Fuse (on power supply): 1 pcs. F 2A, TH 250VAC
- Display: 2x16 characters display (with backlight)
- Keyboard: Keyboard with 5 function keys
- Ambient temperature: 15°C - +40°C (operation)
-25°C - +50°C (storage)
- Relative humidity: 15 - 85% non-condensing
(operation)
< 95% non-condensing (storage)
- Air pressure tolerance: 54.000 - 106.000 Pascal
- Maximum altitude (operation): up to 5000 m

4.1.1 Limits of error and tolerance limits

- Dispense volume: Wash liquid volume adjustable from 50 - 2000µl in increments of 50µl
- Dispensing accuracy: +/- 5% at 300µl across the plate
- Residual volume: +/- 1µl per well

The tolerances of the measuring devices are based on the manufacturer's information.

4.2 General technical data

4.2.1 Dimensions

- Weight: 6,2 kg net
- Dimensions (width x length x height): 21 cm x 46 cm x 21 cm

4.2.2 Power supply

- Consumption: 65VA (maximum)
- Operating voltage: 90-130V, 180-250VAC (autosensing),
frequency range: 50/60 Hz

4.2.3 Interfacing

- Serial interface (RS232 9-pin male connector) for remote control of basic wash functions, instrument status and setup by external PC (with null-modem serial cable used for PC connection).

4.2.4 Options

- liquid level sensors for wash and waste bottles
- 8- and 12-way manifold for 96-well plates
- 16-way manifold for 384-well plates
- Serial interface cable

4.3 Cleaning

This instrument is a precision instrument and it requires regular cleaning to ensure the continued precision.

➤ Liquid spillage

If any liquid is spilled on the instrument, it should be IMMEDIATELY removed so that the liquid does not attack the surface of the housing.

➤ Regular cleaning

The housing of the instrument should be cleaned regularly with a mild household cleaning agent.

Warning: Do not use aggressive solutions!

The area surrounding the plate carrier should be cleaned with a dry cloth.

➤ Fittings and tubing

The wash buffer tends to crystallize easily on air contact and can block tubing and fittings. Use the automatic rinse program daily and do not leave the tubing filled with wash buffer for an extended period of time.

4.4 General features

The Atlantis incorporates state of the art technology and software both necessary to allow optimum performance and easy use.

The Atlantis is designed around your application.

➤ **Easy operation**

Through the menu structure of the on-board software. The display (2x16 characters) and the keyboard with 5 keys provide clear access to all features of the flexible software. If desired the washer may also be operated from a PC using the optional Windows based software.

➤ **8-way manifold**

As standard configuration. Additional manifolds are available as options. The manifold is easily exchanged.

➤ **Up to 3 different wash liquids**

The basic version incorporates 1 liquid line for wash buffer, rinse liquid and waste. The 4 liquid line model can access to up to 3 different wash buffers connected to the instrument which can be selected by software.

➤ **Vacuum and pressure free system**

Any appropriate container can be used to hold the wash buffer. No special bottles are required.

➤ **Quiet operation**

The Atlantis is very quiet due to the special pumps used. Additionally the pumps are only operating when the washing procedure is performed.

➤ **Automatic periodic rinse**

Activate in order to avoid clogging if the washer is not being operated.

➤ **Aerosol Protection**

Cover the manifold and the rear plate position. It can easily be removed for cleaning and maintenance.

➤ **Easy access to all tubes and valves**

All valves and tubes which may require handling by the user are easily accessible to assure fast and convenient maintenance.

➤ **Plate setup**

To optimize the movement of the plate and manifold according to the specific dimensions of different plate types.



Residual volume is minimized by the crosswise aspirate function which aspirates at the edges of the well. Up to 20 different plate types (flat- and round-bottom) can be configured and stored on the instrument.

➤ **Bottom Detection**

As part of the plate setup this unique feature supports optimization of plate specific parameters. The instrument is able to automatically detect the bottom of the well. This results in improved washing performance and minimized residual volume without the manifold touching the bottom of the well (with flat bottom plates only).

➤ **Wash cycles and procedures**

Wash cycles: Up to 20 may be defined according to specific requirements and are stored on the instrument. Once a wash cycle is created it may be used in different wash procedures.

Some of the main features are:

- Bottom and Overflow washing
- Adjustable Dispense volume and speed
- Adjustable aspiration power and time
- Adjustable soak time
- Shaking (3 modes)

Wash procedures: Up to 50 may be created by putting up to 8 previously defined wash cycles in sequence. Washing procedures can either be performed step by step over the whole plate (PLATE-mode) or strip by strip (STRIP-mode). The number of strips to be processed may be defined at the time the wash procedure is started.

➤ **Options**

Liquid level detectors to check volumes in wash and waste bottles.

4.5 Standard delivery content

- Washer Atlantis
- external tubing set
- Manifold (8-way)
- 1 or 3 wash bottles 2 L (depending on configuration)
- Rinse bottle 2 L
- Waste bottle 2.5 L
- Power cord
- User manual

- 
- Spare fuses
 - Cleaning tools for needles

4.6 Warnings and directions

If inflammable, toxic or biologically hazardous substances are used when operating the equipment, please observe the instructions and precautions enclosed with such substances.

Never spill fluids in or on the equipment. Wash your hands thoroughly after handling test fluids.

If the equipment has been in contact with hazardous substances, it must be disinfected prior to shipment in accordance with the effective provisions.

Do not touch the plate during movement of the plate transport (risk of injury).

The equipment may not be opened other than as described in the chapter 11 Maintenance, since it contains live parts (danger to life).

4.7 Unpacking Procedure

1. Visually inspect the container for damage, before opening it.

Note: Report any damage immediately to the forwarding agent or to the delivery carrier.

2. Place the carton in an upright position and open it.
3. Remove the upper cardboard box carefully.
4. Lift the instrument out of the carton and place it on a flat surface, free from dust, vibration and away from direct sunlight.
5. Visually inspect the instrument for loose, bent or broken parts.

Note: Report any damage immediately.

6. Compare the instrument's serial number, attached on the rear panel of the instrument, against the serial number of the instrument on the delivery (shipping) note and packing list.
6. Check the instrument accessories against the delivery (shipping) note and packing list.
7. **Please save all packing materials, as they may be required for later transportation.**

4.8 Installation requirements, Environmental operating conditions

- Flat, dry, clean and vibration-proof working area (50 cm x 35 cm - length x width)
- Additional room for cables, connections, etc.
- No direct sunlight
- Clean ambient air (free of corrosive vapors, smoke and dust)
- Ambient temperature between 15°C and 40°C
- Humidity between 15% and 85%.
- Before the instrument is installed and switched on, it should be left to stand for at least 2 hours, so there is no possibility of condensation causing a damage or malfunction.
- Use the power cable supplied with the instrument to connect the instrument's main plug with a power outlet providing protective earth.

Please Note:

Only use the power cable supplied with the instrument or a power cable with protective earth connection carrying the CE-mark.

Please ensure that the power outlet used has the applicable technical safety requirements!

4.9 Instrument installation procedure

The following procedures detail the necessary steps to be followed when installing the Instrument.

1. Place the instrument into the required position

Note: Ensure the distance between the back panel of the instrument and the wall, is at least 5 cm.

Remove all packing material and transport lock tapes.

2. Remove all packing material from the manifold. Look for the two manifold connecting tubes, packed together with the manifold. Connect the aspiration tube with the red quick fit connector to the corresponding connector at the top plate of the washer and slide the other end of the tubing on the red connector of the manifold. Now connect the thin dispense tubing with the blue quick fit connector to the corresponding connector. Press down now the black pinch valve actuator and slide the dispense tube into the side slot of the pinch valve. Make sure that the tubing is fully inside the valve. Afterwards slide the dispense tube on the blue connector of the manifold.

Place the manifold now on the horizontal manifold holder bar so that the two holding pins are resting in the slots of the manifold holder.

3. Connect the long aspiration tube with the red fitting to the connector at the backside of the washer and to the waste bottle.
4. Connect the wash fluid tube with blue fitting to the connector at the backside of the washer and to the wash bottle.
5. Connect the rinse fluid tube with the white fitting to the connector at the backside of the washer and to the rinse bottle.
6. Ensure that the mains power switch at the back panel of the instrument is in the OFF position.
7. Insert the power cable into the mains power socket in the back panel of the instrument.
8. Switch the washer on.

If the instrument is turned on using the power switch on the rear side of the device the green power indicator on the left front side of the device has to be illuminated.

When connecting the instrument with an external computer, ensure the instrument is switched off (the power indicator is dark). If the instrument is turned on turn it off using the power switch on the rear side of the device.



The power indicator is located on the front left side of the unit and is marked with the following symbol.



The stand-by indicator may show 3 different states:

Green light: Instrument is in stand-by (ready for operation).

Not illuminated: Instrument is not ready for operation.

In order to make sure the instrument is disconnected from power the main switch on the rear side of the unit has to be switched to the "OFF-position" indicated with a "0" symbol. Alternatively the power cord can be disconnected from the unit.

4.10 Re-packing to prevent damage during transport

The original Atlantis packing has been specially designed for this equipment.

1. Remove the manifold and tubing and the plate carriage and pack them into the accessories boxes.
2. Lock the holder of the manifold with the foam part as shown in picture 1.
3. Put the transport lock plate at the location shown in picture 2 and secure the plate with adhesive tape.
4. Place the foam parts left and right on the washer and put the washer into the transport box. (Picture 3).
5. Place the the bottles and the accessory boxes into the spaces left and right of the instrument as shown on picture 3.

It is therefore recommended to save the original carton with its foam parts and accessories box. Warranty claims are void if transport damages are caused by improper packing!



picture 1

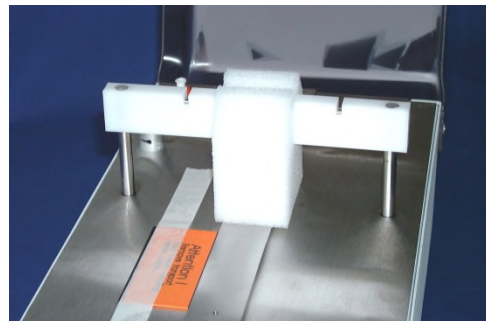

picture 2



picture 3



5 Theory of Operation

5.1 Introduction

This chapter gives the description of the main components of the instrument and describes the hydraulic system.

5.2 Main components

The main components of the washer are the control electronics, the plate transport mechanism, the manifold transport, the dispensing and aspirating pumps, the keyboard with the LCD display and the power supply unit.

5.3 Hydraulic system

5.3.1 Dispensing system

The dispensing system consists of the input selection valves, the diaphragm pump, the damping tube, the pinch valve and the manifold. The input selection valves are connecting the respective liquid reservoirs (wash and rinse solution) to the internal dispense circuits. The valves are controlled by the washer software to select the correct liquid. The dispensing pump delivers the liquid to the manifold, the operating time of the pump together with the operating time of the pinch valve are controlling the programmed volume.

5.3.2 Aspirating system

The aspiration is performed by a liquid pump connected to the aspiration needles of the manifold. Compared to the traditional vacuum pump operation this method produces much less noise and does not require sealed bottles. Any kind of container with sufficient volume can be used for the waste. In addition the risk of infectious aerosols is much reduced.

Diagram1.: Hydraulic Diagram

Liquid Flow Diagram

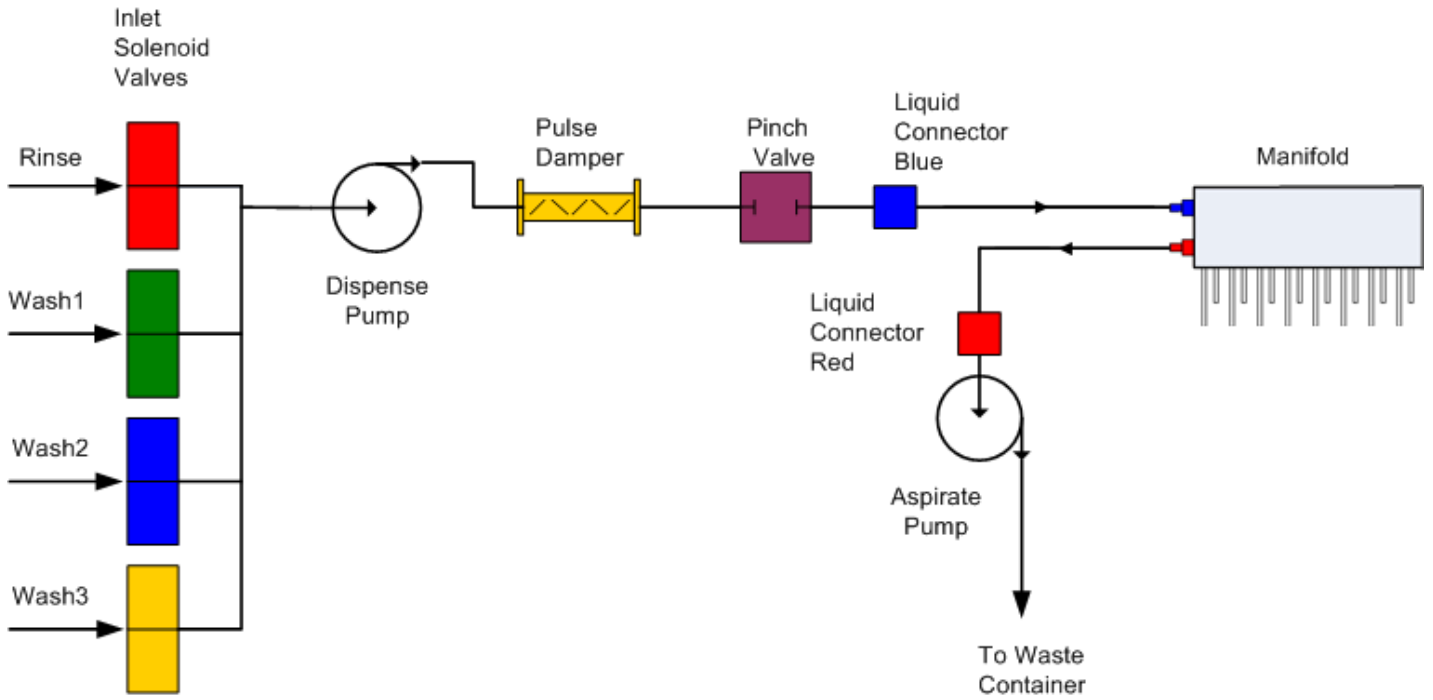

6 Warranty

Warranty shall lose effect if:

- Atlantis is not used in the defined scope of application,
- Atlantis has obviously been damaged by external influences which are not in accordance with the provisions for the nominal range of use,
- Atlantis has been modified or parts exchanged by a person other than Biochrom personnel or an authorized servicing agent,
- The warranty seals on the housing of the instrument are broken,
- The parts and subassemblies are implemented, which are not original from Biochrom,
- The Atlantis serial number is no longer legible, has been removed or altered,
- The Atlantis has not been installed in accordance with the instructions supplied,
- The Atlantis has been damaged during return transport due to wrong packing (e.g. not in original packing material).
- The Atlantis was damaged due to wrong operation, not according to the descriptions in the manual.

The instrument may only be operated by qualified personnel.

If a warranty is brought into operation, Biochrom shall repair or replace any defects which have resulted from faulty material or during production as it check fit. No costs shall arise for the client (except cargo rates).

All components found in the original equipment, or an adequate and full compatible alternative shall be available for a period of 5 (five) years after production.

This warranty refers to the obligations of Biochrom and can only be amended upon the written consent of Biochrom.

6.1 Liability

In original condition the instrument meets all safety regulations for a risk-less operation.

Biochrom cannot warrant damages or any resulting costs caused by alterations, repairs or modifications of the equipment.

7 Software Principle

7.1 Software Navigation

Drawing 2.: Software Navigation

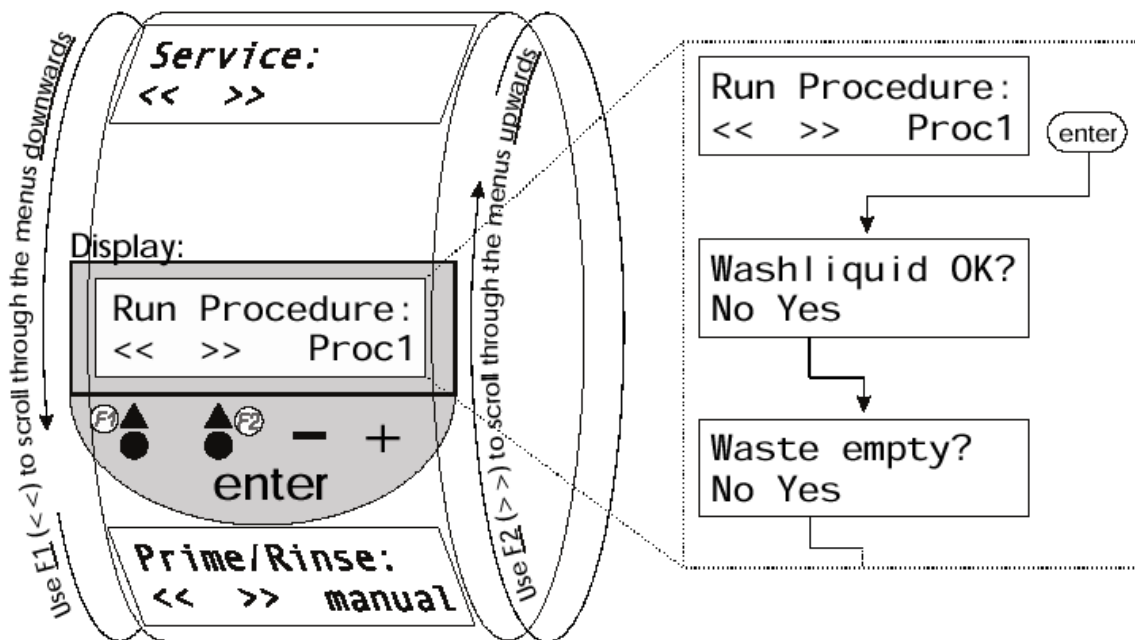

The software was designed to make navigation through the different menus as easy as possible. The main menus are organized like a wheel which can be turned in both directions by means of the two first keys (function key 1 <F1> and function key 2 <F2>). When pressing <F1> or <F2> the next respectively the previous menu will be displayed.

The two function keys may have different functions assigned in the various sub-menus. The current assignment is always displayed right above the corresponding key.

The lower right of the display will show the current selection of different options (e.g. "Proc1" for the procedure with this name). To change the selection use the <+> and <-> keys. These keys can also be used for numerical or alphanumeric inputs by means of in- or decreasing a value or scrolling through the alphabet.

By pressing <enter> the current selection is confirmed and the software leads to the next menu to allow further selections.

7.2 Programming Sequence

The software offers the possibility to program up to 50 so-called *procedures* (a procedure defines a complete wash program). To define a procedure *cycles* (defines one part - cycle - of a wash program; e.g. bottom wash) and *plates* (defines the shape and measures of the plate used) are necessary.

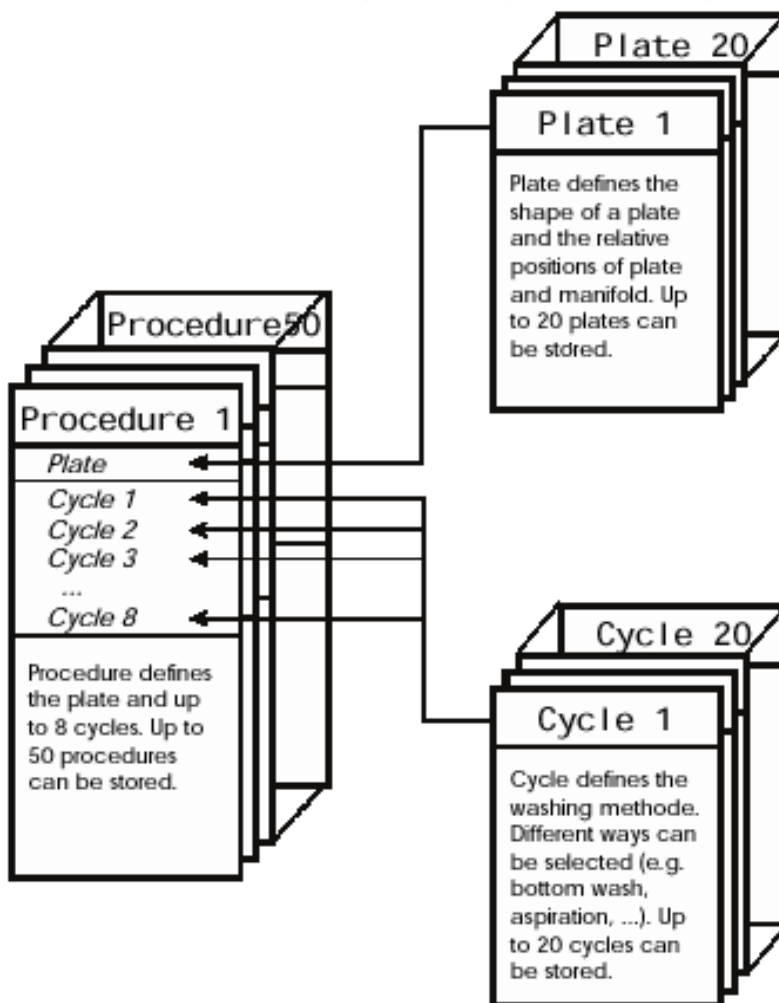

Drawing 3. Software Principle

Note: Please make sure to program the cycle and plate BEFORE the procedure!



7.3 Menus

The following flow diagrams give an overview of all menus and the way of navigating through them. Detailed information for all menus and their functions can be found in the following chapters.

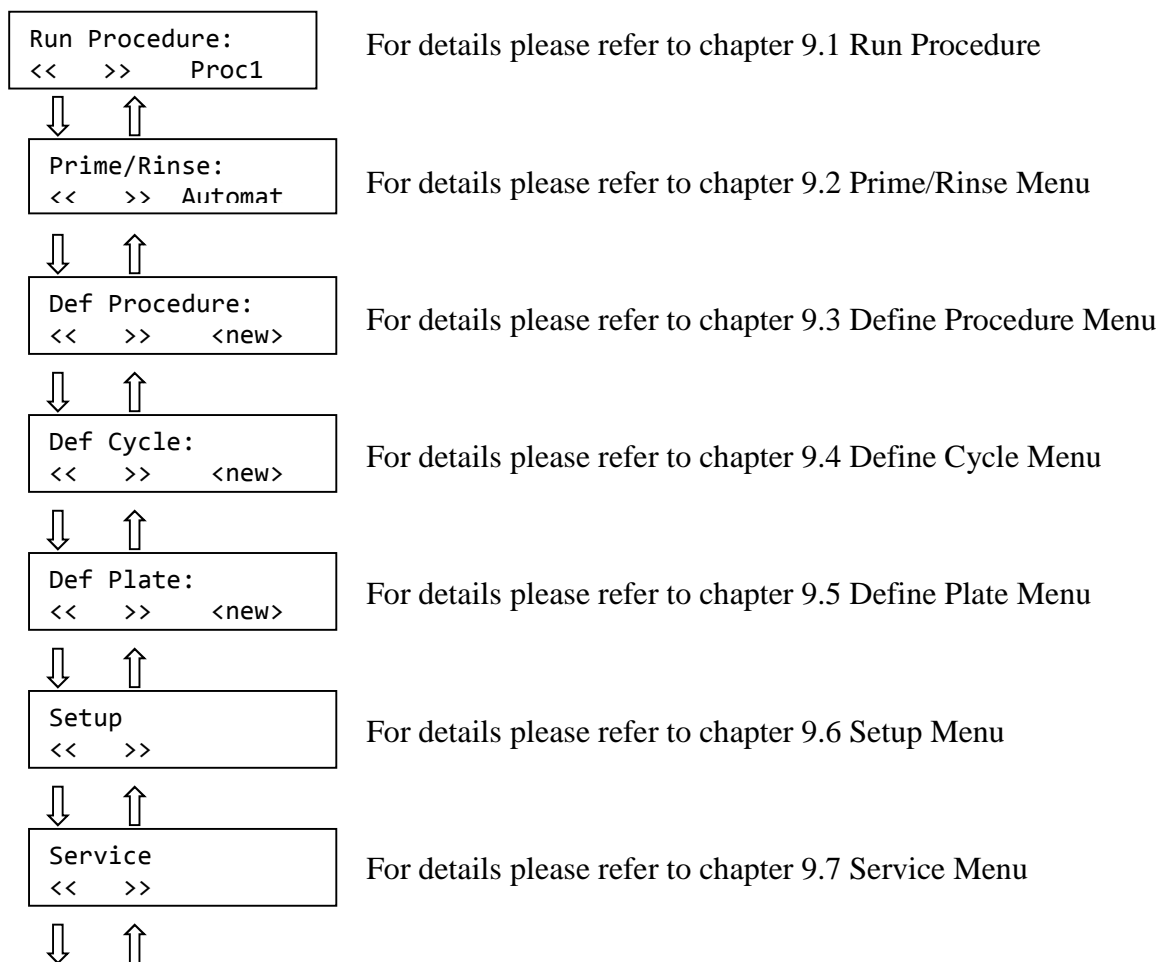

7.3.1 Run Procedure

Table 1 Run Procedure

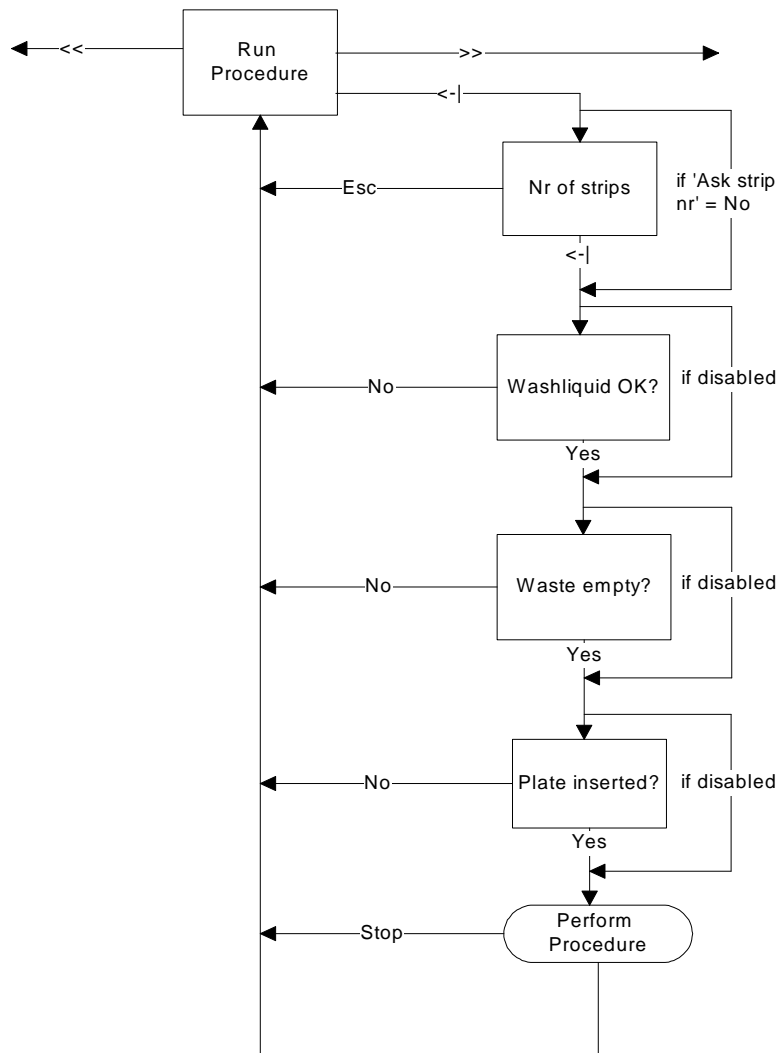

For details please refer to chapter 9.1 Run Procedure

7.3.2 Prime / Rinse

Table 2. Prime / Rinse

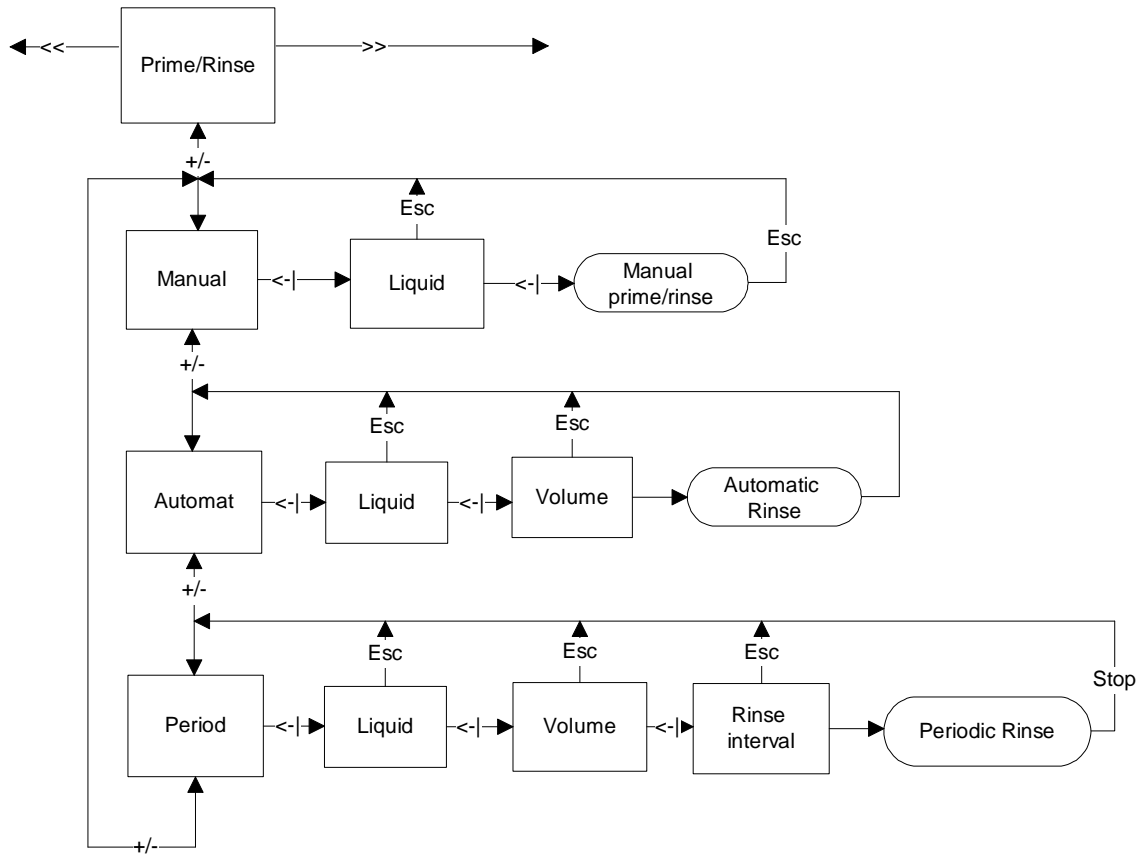

For details please refer to chapter 9.2

7.3.3 Define Procedure

Table 3. Define Procedure

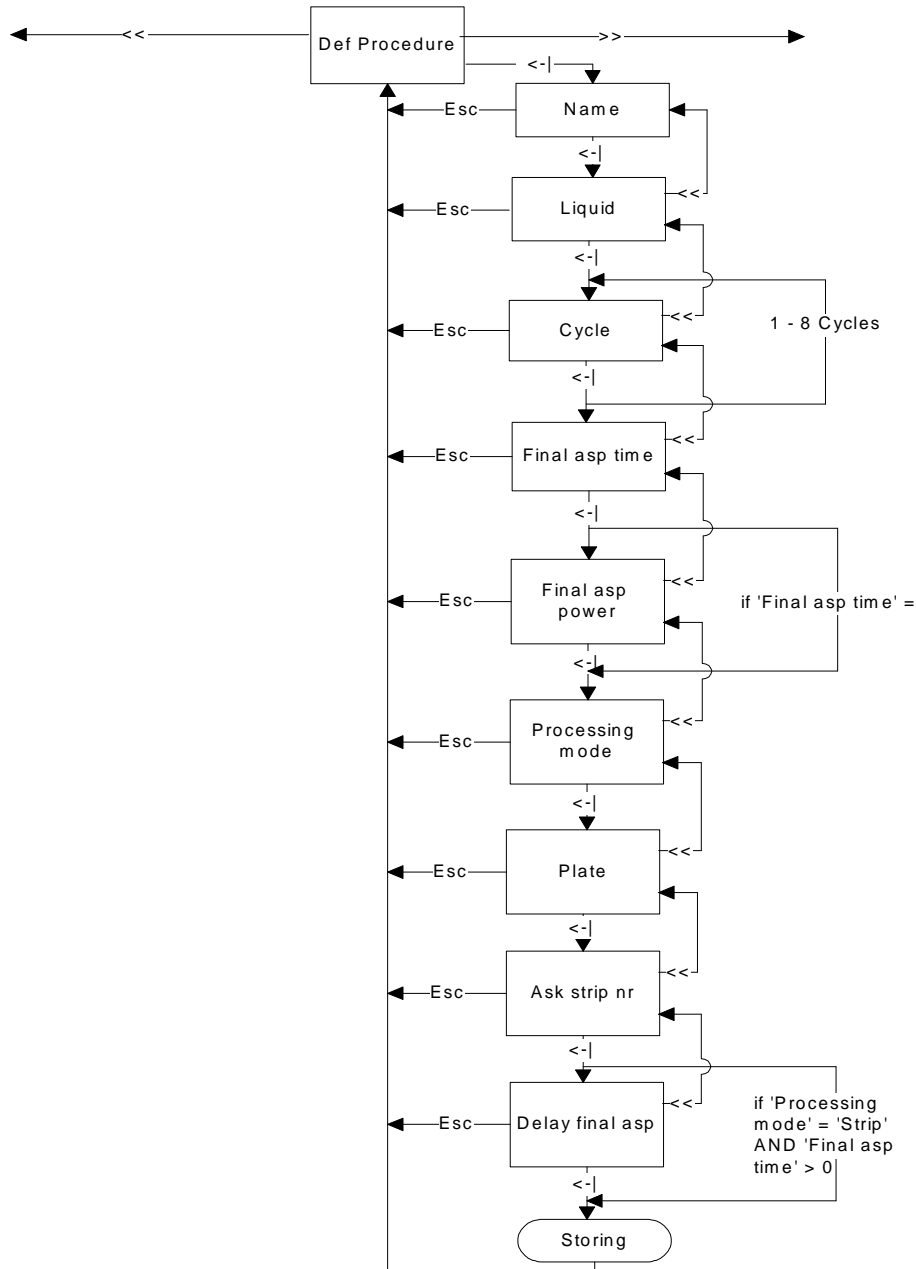

For details please refer to chapter 9.3 Define Procedure Menu

7.3.4 Define Cycle

Table 4. Define Cycle

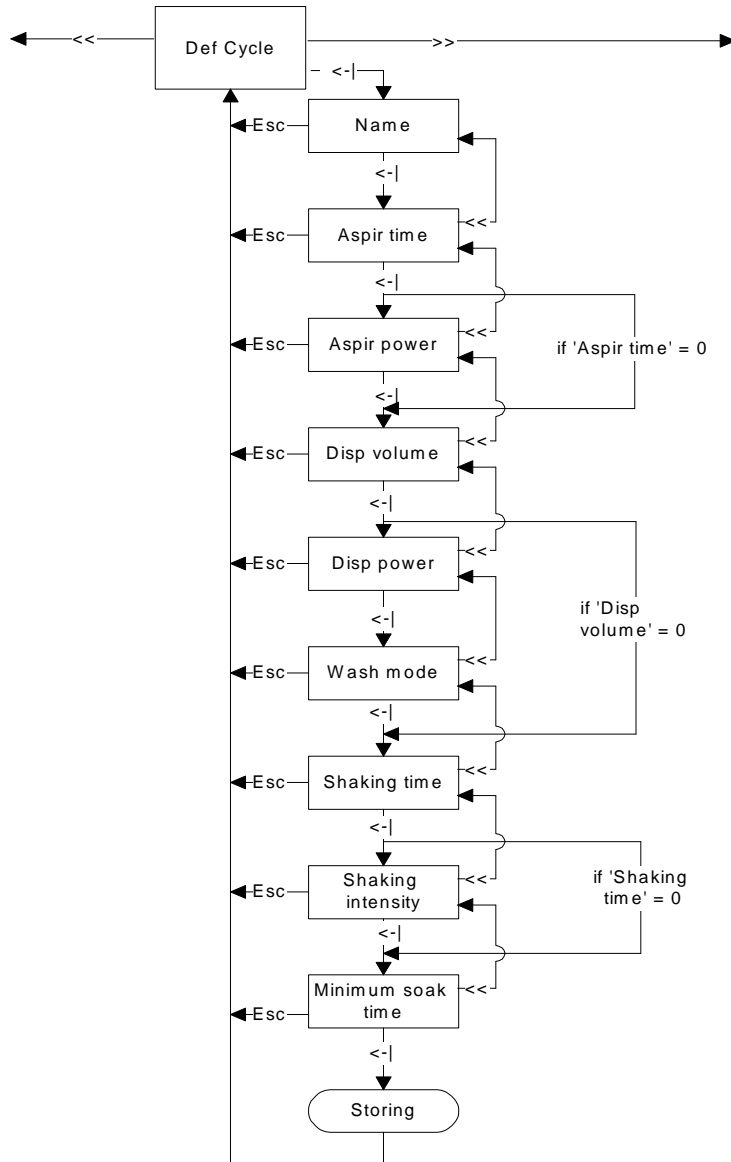

For details please refer to chapter 9.4 Define Cycle Menu

7.3.5 Define Plate

Table 5. Define Plate

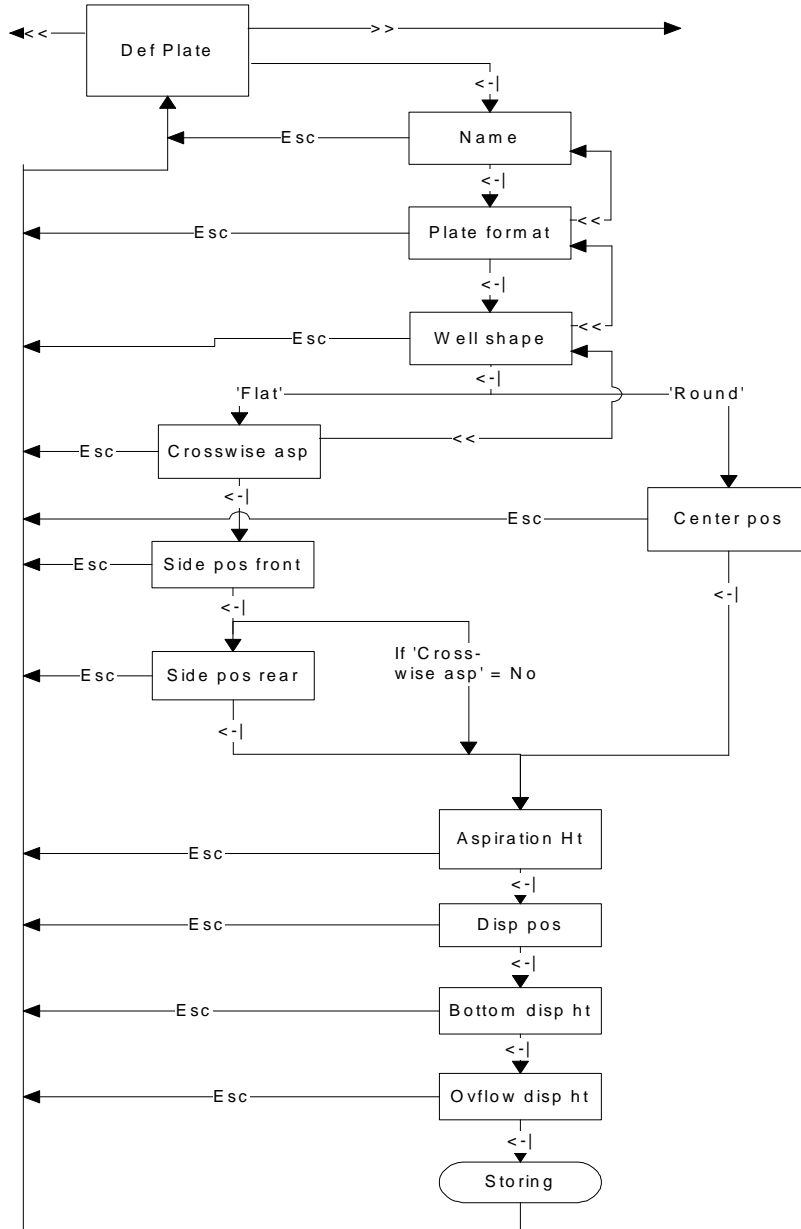

For details please refer to chapter 9.5 Define Plate Menu

7.3.6 Setup

Table 6. Setup

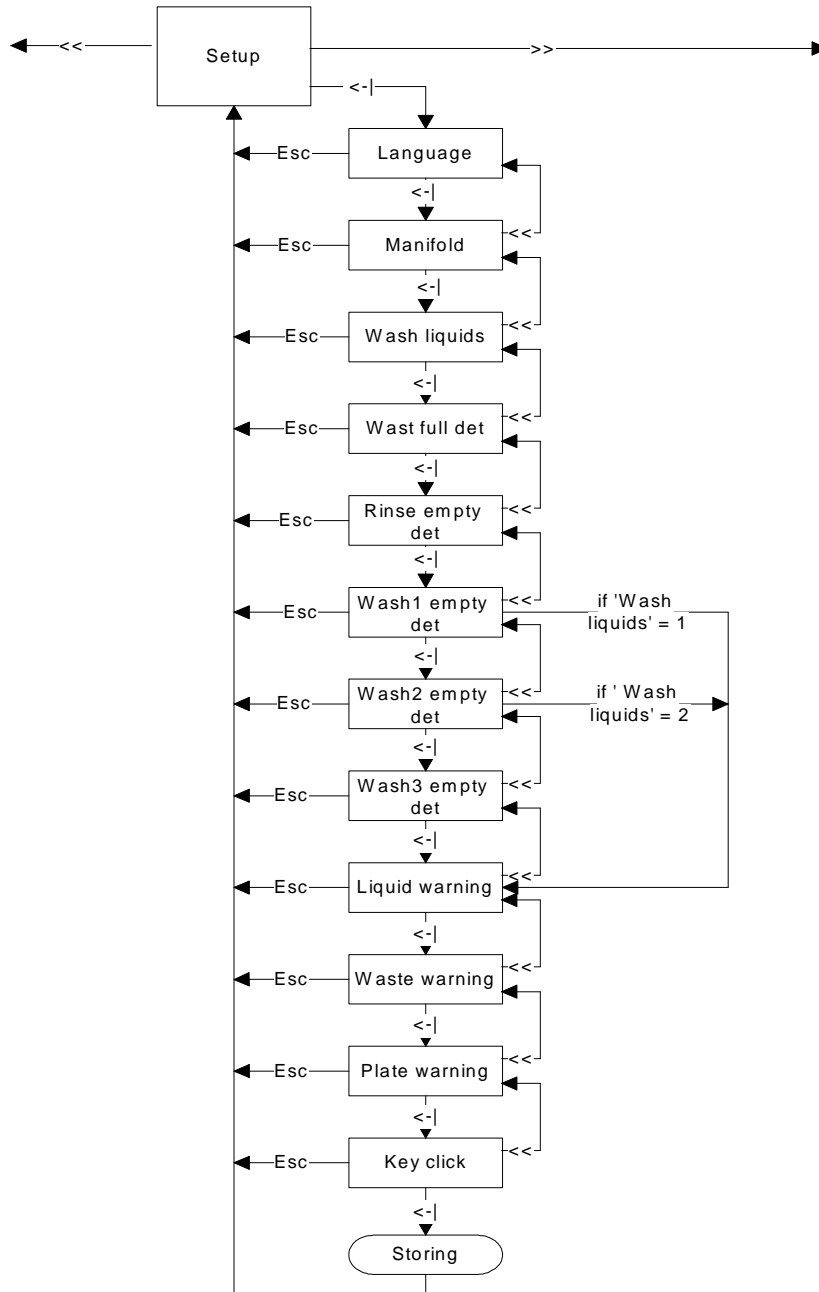

For details please refer to chapter 9.6 Setup Menu

7.3.7 Service

Table 7. Service

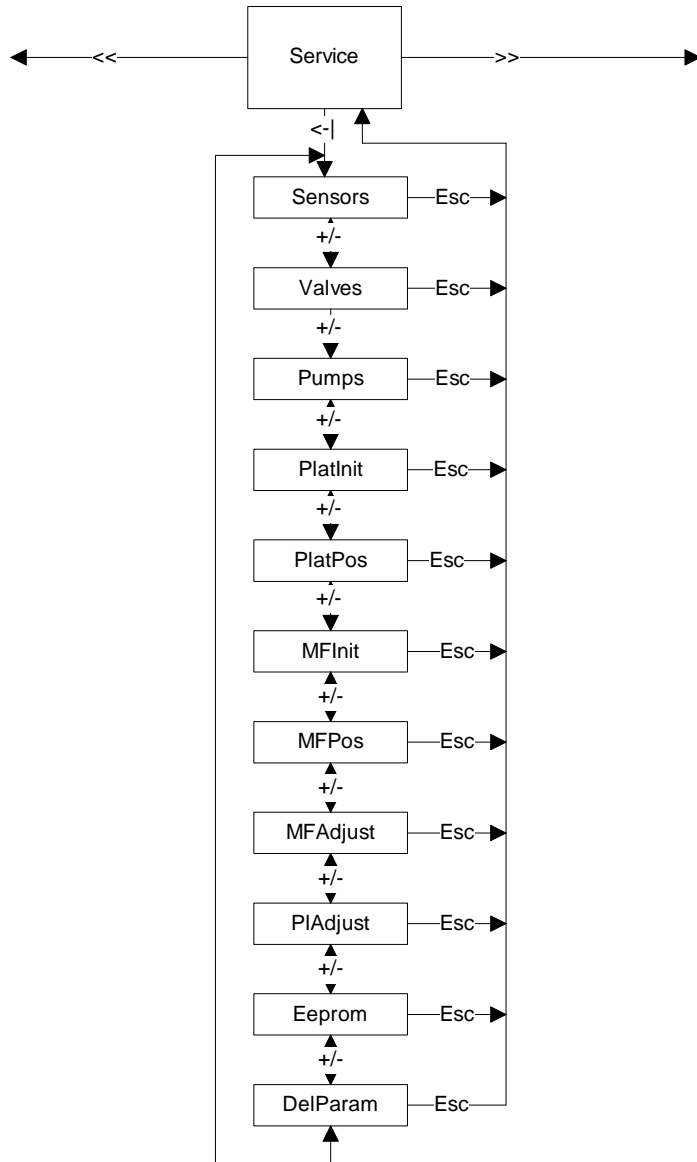

For details please refer to chapter 9.7 Service Menu



7.4 Description of the key functions

<F1> / <F2> - Function Keys: Used to scroll through the different menus. Depending on the menu, other functions can be assigned to these keys. The current function is always shown in the display right above the key.

<+> / <-> - These keys are used for numerical or text input and to select options from a list (e.g. selection of the procedure to be started).

<enter> - confirms the text / numerical entry or selection and proceeds to the next dialogue element.

8 Start-up and system setup

8.1 Start-Up

- Place the device on a suitable working surface
- Follow the steps described in the chapters 4.8 Installation requirements, Environmental operating conditions and 4.9 Instrument installation procedure
- Connect power cable to standard mains plug
- Switch on main switch (rear left side). The Atlantis performs the complete initialization and shows the main menu after approx. 10 seconds. Display

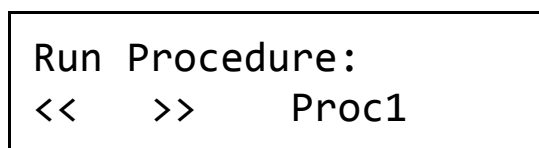

Screen 8. Display

➤ **Description:**

The first line of the display shows the name of the menu or the current function of a sub-menu.

The second line is split into 3 parts:

<< - current function assigned to the first function key
(e.g. previous menu, escape, ...)

>> - current function assigned to the second function key
(e.g. next menu, escape, ...)

Proc1 - current selection (or field for text or numerical input); use the <-> and <+> keys to alter a selection or change a value

8.2 Control of the system setup



Screen 9. Setup Menu

Please make sure to set all options according to your requirements before programming new procedures, plates or cycles and before running procedures. For details on this menu please refer to chapter 9.6 Setup Menu

9 Programming

9.1 Run Procedure

```
Run Procedure:
<<   >>   Proc1
```

Screen 10. Run Procedure

In this menu you can select the procedure to be started. All procedures defined in the "Define Procedure Menu" can be selected.

➤ **Function keys:**

<F1> or <F2>

Select another menu.

<+> or <->

Select a procedure to be started.

<enter>

Confirm the selection of the procedure and go to the next screen.

```
Wash liquid OK?
No   Yes
```

Screen 11. Wash liquid Check

A warning to check the liquid level of the wash bottle is displayed (this function needs to be activated in the "Setup Menu").

➤ **Function keys:**

<F1> or <F2>

Select "Yes" or "No". If "No" is selected the instrument will return to the main menu.

Waste empty?
No Yes

Screen 12. Waste Check

A warning to check the liquid level of the waste bottle is displayed (this function needs to be activated in the "Setup Menu").

➤ **Function keys:**

<F1> or <F2>

Select "Yes" or "No". If "No" is selected the instrument will return to the main menu.

Warning: *If "Yes" is selected without a sufficient volume for waste liquid in the waste bottle the instrument can be damaged!*

Plate inserted?
No Yes

Screen 13. Plate Check

A warning to check whether a plate is inserted is displayed (this function needs to be activated in the "Setup Menu").

➤ **Function keys:**

<F1> or <F2>

Select "Yes" or "No". If "No" is selected the instrument will return to the main menu.

Warning: *If "Yes" is selected without a plate inserted to the instrument spillage will be caused which can damage the instrument and/or be harmful to the ambient (depending on the used wash liquid)!*

Nr of strips:
Esc 12

Screen 14. Nr of stripes check

The display prompts you to enter the right numbers of strips (this function needs to be activated in the "Setup Menu").

➤ **Function keys:**

<F1>

Select Esc: the instrument will return to the main menu

<->/<+>

Select number of strips

<enter>

Confirms the selection and starts procedure

After confirmation of the above warnings the selected procedure will be started. During the run the display will show the currently performed cycles.

9.2 Prime/Rinse Menu

```
Prime/rinse:  
<<  >>  Manual
```

Screen 15. Prime/rinse Menu

This menu is used to configure a manual, automatic or periodic prime / rinse cycle(s).

➤ **Function keys:**

<F1> or <F2>

Select another menu.

<+> or <->

Select the desired mode for prime / rinse. Available options are: manual, automatic, periodic

<enter>

Confirm the selection of the prime / rinse mode and go to the next screen.

9.2.1 Manual Prime/Rinse

```
Liquid:  
Esc      Wash 1
```

Screen 16. Liquid Selection

Select the liquid to be used for prime / rinse.

➤ **Function keys:**

<F1> or <F2>

Select "Esc" to return to the main menu.

<+> or <->

Select the desired liquid.

<enter>

Confirm the selection of the liquid and go to the next screen.

Manual Pri/Rinse Esc Go

Screen 17. Manual Prime/rinse

The prime / rinse can be started with the corresponding function key ("Go") and will be performed as long as this key is pressed.

➤ **Function keys:**

<F1> or <F2>

Select "esc" to return to the main menu or "Go" to start the prime / rinse (keep this key pressed as long as you like the prime / rinse to be performed).

9.2.2 Automatic Prime/Rinse

Liquid: Esc Wash 1

Screen 18. Liquid Selection

Select the liquid to be used for prime / rinse.

➤ **Function keys:**

<F1> or <F2>

Select "Esc" to return to the main menu.

<+> or <->

Select the desired liquid.

<enter>

Confirm the selection of the liquid and go to the next screen.

Volume: Esc 50 ml

Screen 19. Volume Selection

Select the liquid volume for prime / rinse.

➤ **Function keys:**

<F1> or <F2>

Select "Esc" to return to the main menu.

<+> or <->

Select the desired volume in 1ml steps (max. 200ml).

<enter>

Confirm the selection of the liquid volume and go to the next screen.

```
Start Pri/Rinse
Esc
```

Screen 20. Start Prime / Rinse

➤ **Function keys:**

<F1> or <F2>

Select "Esc" to return to the main menu.

<enter>

Press <enter> to start the prime / rinse cycle with the above set parameters.

```
P/R in process
Stop
```

Screen 21. Status Message

➤ **Function keys:**

<F1> or <F2>

Select "Stop" to cancel the current prime / rinse cycle and return to the main menu.

9.2.3 Periodic Prime/Rinse

```
Liquid:
Esc      Wash 1
```

Screen 22. Liquid Selection

Select the liquid to be used for prime / rinse.

➤ **Function keys:**

<F1> or <F2>

Select "Esc" to return to the main menu.

<+> or <->

Select the desired liquid.

<enter>

Confirm the selection of the liquid and go to the next screen.

Volume: Esc 50 ml
--

Screen 26. Volume Selection

Select the liquid volume for periodic prime / rinse.

➤ **Function keys:**

<F1> or <F2>

Select "Esc" to return to the main menu.

<+> or <->

Select the desired volume in 1ml steps (max. 200ml).

<enter>

Confirm the selection of the liquid volume and go to the next screen.

Rinse Period: esc 10 min

Screen 23. Rinse Period Selection

Select the period of time after which the instrument is rinsed.

➤ **Function keys:**

<F1> or <F2>

Select "Esc" to return to the main menu.

<+> or <->

Select the desired time period in steps of 1min (max. 200min).

<enter>

Confirm the selection of the time and go to the next screen.



```
Start Pri/Rinse
esc
```

Screen 24. Start Prime / Rinse

➤ **Function keys:**

<F1> or <F2>

Select "Esc" to return to the main menu.

<enter>

Press <enter> to start the prime / rinse cycle with the above set parameters.

```
Periodic rinse
Stop
```

Screen 25. Status Message

➤ **Function keys:**

<F1> or <F2>

Select "Stop" to cancel the current prime / rinse cycle and return to the main menu.

9.3 Define Procedure Menu

```
Def Procedure:
<<  >>  <new>
```

Screen 26. Define Procedure Menu

In this menu a procedure can be defined. Every procedure contains one or more cycles and a plate. The cycles and the plate must be defined prior to the procedure.

➤ **Function keys:**

<F1> or <F2>

Select another menu.

<+> or <->

Select "<new>" to define a new procedure or select an existing procedure to edit it.

<enter>

Confirm the selection of the procedure and go to the next screen.

Name:
Esc Sel A_

Screen 27. Procedure Name Entry

The name of the procedure may be changed.

➤ **Function keys:**

<F1> or <F2>

Select "Chg" to change the name for the procedure.

Name:
Esc Chg 1

Screen 28. Procedure Name Entry

➤ **Function keys:**

<F1> or <F2>

Select "Esc" to return to the main menu without saving any changes or "Sel" to select the current letter/number.

<+> or <->

Use these keys to scroll through the available letters (A-Z) and numbers (0-9)

<enter>

Confirm the name of the procedure and go to the next screen.

Liquid:
<< Esc Wash 1

Screen 29. Wash Liquid Selection

Select the wash liquid to be used for this procedure.

➤ **Function keys:**

<F1> or <F2>

Select "Esc" to return to the main menu without saving any changes or "<<" to return to the previous screen.

<+> or <->

Use these keys to enter the wash liquid.

<enter>

Confirm the wash liquid and go to the next screen.

Cycle1:
<< Esc C1

Screen 30. Cycle1 Selection

Select the first cycle to be used for this procedure. The cycles must be defined in the "Define Cycle Menu" prior to the definition of the procedure.

➤ **Function keys:**

<F1> or <F2>

Select "Esc" to return to the main menu without saving any changes or "<<" to return to the previous screen.

<+> or <->

Use these keys to scroll through the available cycles.

<enter>

Confirm the selection of the first cycle and go to the next screen.

Cycle2:
<< Esc ---

Screen 31. Cycle2-8 Selection

Select the cycles 2 to 8 to be used for this procedure. The cycles must be defined in the "Define Cycle Menu" prior to the definition of the procedure. By selecting "---" the previous cycle will be the last cycle in the procedure.

➤ **Function keys:**

<F1> or <F2>

Select "Esc" to return to the main menu without saving any changes or "<<" to return to the previous screen.

<+> or <->

Use these keys to scroll through the available cycles.

<enter>

Confirm the selection of the cycle and go to the next screen.

Final asp time:
<< Esc 0 sec

Screen 32. Final Aspiration Time Entry

Select the duration of the final aspiration.

➤ **Function keys:**

<F1> or <F2>

Select "Esc" to return to the main menu without saving any changes or "<<" to return to the previous screen.

<+> or <->

Use these keys to enter the time for the final aspiration in steps of 1sec (max. 10 seconds).

<enter>

Confirm the final aspiration time and go to the next screen.

```
Final asp speed:
<<  Esc      High
```

Screen 33. Final Aspiration Power Entry

Select the power for the final aspiration.

➤ **Function keys:**

<F1> or <F2>

Select "Esc" to return to the main menu without saving any changes or "<<" to return to the previous screen.

<+> or <->

Use these keys to enter the power for the final aspiration ("Low", "Medium", "High").

<enter>

Confirm the final aspiration power and go to the next screen.

```
Processing mode:
<<  Esc      Plate
```

Screen 34. Processing Mode

Select the processing mode to be used for this procedure.

➤ **Function keys:**

<F1> or <F2>

Select "Esc" to return to the main menu without saving any changes or "<<" to return to the previous screen.

<+> or <->

Use these keys to scroll through the available modes ("Plate" or "Strip").

<enter>

Confirm the selection of the processing mode and go to the next screen.



```
Plate:
<<  Esc      FB1
```

Screen 35. Plate Selection

Select the plate to be used for this procedure. The plate must be defined in the "Define Plate Menu" prior to the definition of the procedure.

➤ **Function keys:**

<F1> or <F2>

Select "Esc" to return to the main menu without saving any changes or "<<" to return to the previous screen.

<+> or <->

Use these keys to scroll through the available plates.

<enter>

Confirm the selection of the plate and go to the next screen.

```
Ask strip nr:
<<  Esc      No
```

Screen 36. Ask for Last Strip

Select "Yes" if the selection of a "number of strips" should be possible every time this procedure is started. This can be useful if for example full plates and plates with just a few strips are used subsequently with the same procedure.

➤ **Function keys:**

<F1> or <F2>

Select "Esc" to return to the main menu without saving any changes or "<<" to return to the previous screen.

<+> or <->

Use these keys to toggle between "Yes" and "No". If "Yes" is selected you can define the last strip every time the procedure is started. "No" means that every time all strips of a plate are washed.

<enter>

Confirm the selection and go to the next screen.

```
Delay final asp:
<<  Esc      Yes
```

Screen 37. Delay of Final Aspiration

Select "Yes" to delay the final aspiration of the plate. This is used in strip mode: The final aspiration is performed only after the last cycle in the last filled strip is done and the soak time has expire

➤ **Function keys:**

<F1> or <F2>

Select "Esc" to return to the main menu without saving any changes or "<<" to return to the previous screen.

<+> or <->

Use these keys to toggle between "Yes" and "No". If "Yes" is selected the final aspiration is performed after the last cycle for all strips is finished.

<enter>

Confirm the selection. The set parameters will be stored and the program returns to the main menu.

9.4 Define Cycle Menu

Def Cycle: << >> <new>

Screen 38. Define Cycle Menu

This menu defines the parameters of a cycle. A cycle is required to define a complete wash-procedure.

➤ **Function keys:**

<F1> or <F2>

Select another menu.

<+> or <->

Select "<new>" to define a new cycle or select an existing cycle to edit it.

<enter>

Confirm the selection of the cycle and go to the next screen.

Name: Esc Chg 1

Screen 39. Cycle Name Entry

The name of the cycle may be changed.

➤ **Function keys:**

<F1> or <F2>

Select "Chg" to change the name for the cycle.

Name:
Esc Sel A_

Screen 40. Cycle Name Entry

➤ **Function keys:**

<F1> or <F2>

Select "Esc" to return to the main menu without saving any changes or "Sel" to select the current letter/number.

<+> or <->

Use these keys to scroll through the available letters (A-Z) and numbers (0-9)

<enter>

Confirm the name of the cycle and go to the next screen.

Aspiration time:
<< Esc 5 sec

Screen 41. Aspiration Time Entry

➤ **Function keys:**

<F1> or <F2>

Select "Esc" to return to the main menu without saving any changes or "<<" to return to the previous screen.

<+> or <->

Use these keys to change the aspiration time (the time the manifold remains inside a well during aspiration) in steps of 1sec (range: 0 - 10 seconds).

<enter>

Confirm the selection of the aspiration time and go to the next screen.

Aspir power:
<< Esc High

Screen 42. Aspiration Power Entry

➤ **Function keys:**

<F1> or <F2>

Select "Esc" to return to the main menu without saving any changes or "<<" to return to the previous screen.

<+> or <->

Use these keys to change the power with which the liquid is aspirated off a well ("Low", "Medium", "High").

<enter>

Confirm the selection of the aspiration power and go to the next screen.

```
Disp volume:  
<< Esc 1000 µl
```

Screen 43. Dispense Volume Entry

➤ **Function keys:**

<F1> or <F2>

Select "Esc" to return to the main menu without saving any changes or "<<" to return to the previous screen.

<+> or <->

Use these keys to change the dispense volume for this cycle in steps of 50µl (range 0 - 2000µl).

<enter>

Confirm the selection of the volume and go to the next screen.

```
Disp power:  
<< Esc High
```

Screen 44. Dispenser Power Selection

➤ **Function keys:**

<F1> or <F2>

Select "Esc" to return to the main menu without saving any changes or "<<" to return to the previous screen.

<+> or <->

Use these keys to change the power (pressure) of the liquid for dispensing ("Low", "Medium", "High").

<enter>

Confirm the selection of the dispensing power and go to the next screen.

```
Wash mode:  
<< Esc Overflow
```

Screen 45. Wash Mode Selection

Two different wash modes are available:

Bottom: the needles of the manifold are placed into the well (to the defined position for the used plate) during the wash procedure. This means that basically only the bottom of the well is washed.

Overflow: the needles of the manifold are placed to a certain position above the well (to be also defined in the "Define Plate Menu"). Therefore the whole well is thoroughly washed as the wash solution is only aspirated after it fills the well up to the defined position and reaches the aspiration needles of the manifold.

➤ **Function keys:**

<F1> or <F2>

Select "Esc" to return to the main menu without saving any changes or "<<" to return to the previous screen.

<+> or <->

Use these keys to toggle between "Bottom" and "Overflow".

Shaking time: << Esc 5 sec

Screen 46. Shaking Time Entry

➤ **Function keys:**

<F1> or <F2>

Select "Esc" to return to the main menu without saving any changes or "<<" to return to the previous screen.

<+> or <->

Use these keys to change to shaking time in steps of 1sec (range: 0 - 10 seconds).

<enter>

Confirm the selection of the shaking time and go to the next screen.

Shaking intens: << Esc Medium

Screen 47. Shaking Intensity Entry

➤ **Function keys:**

<F1> or <F2>

Select "Esc" to return to the main menu without saving any changes or "<<" to return to the previous screen.

<+> or <->

Use these keys to change the intensity for shaking ("Low", "Medium", "High").

<enter>

Confirm the selection of the shaking intensity and go to the next screen.

```
Min soak time:  
<< Esc 10 sec
```

Screen 48. Minimum Soaking Time Entry

The minimum soaking time defines the time which must elapse at least between dispensing and aspirating a well.

➤ **Function keys:**

<F1> or <F2>

Select "esc" to return to the main menu without saving any changes or "<<" to return to the previous screen.

<+> or <->

Use these keys to change the minimum soaking time in steps of 10sec (range: 0 - 1000 seconds).

<enter>

Confirm the selection of the minimum soaking time. The set parameters will be stored and the program returns to the main menu.

9.5 Define Plate Menu

The following drawings help to find the correct positions of the manifold and plate. Please note that curved bottom plates do not allow crosswise aspiration!

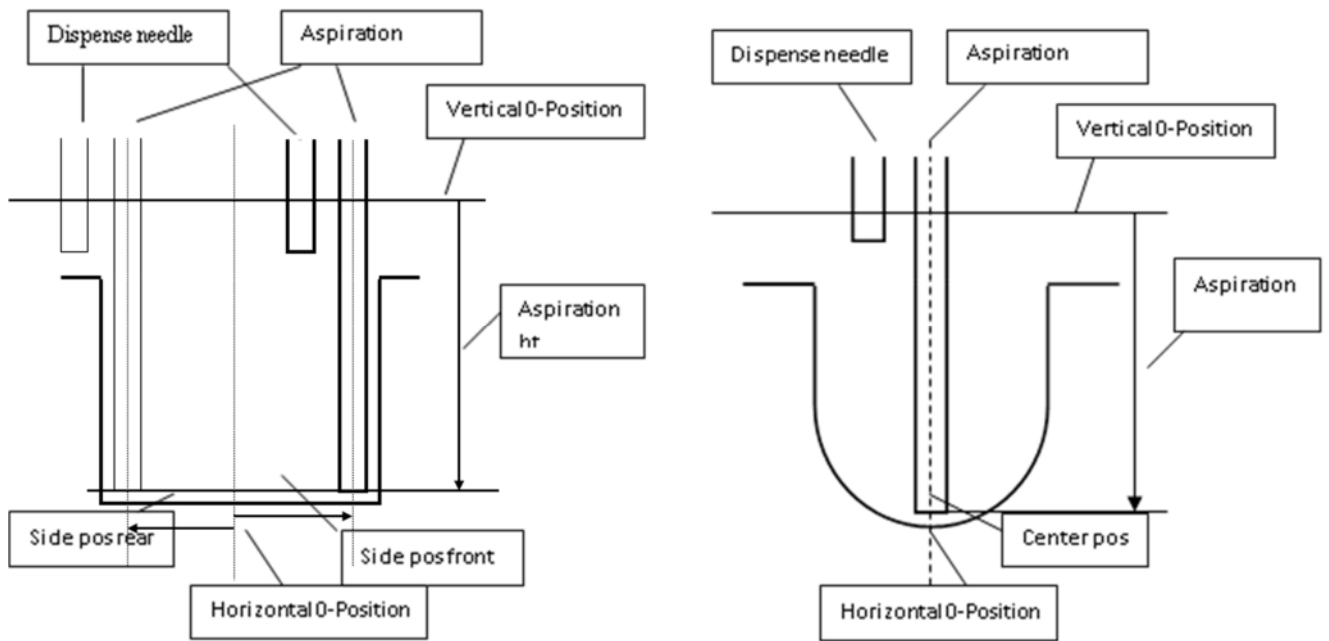

Drawing 49.: Aspiration Positions for flat bottom or curved bottom plates

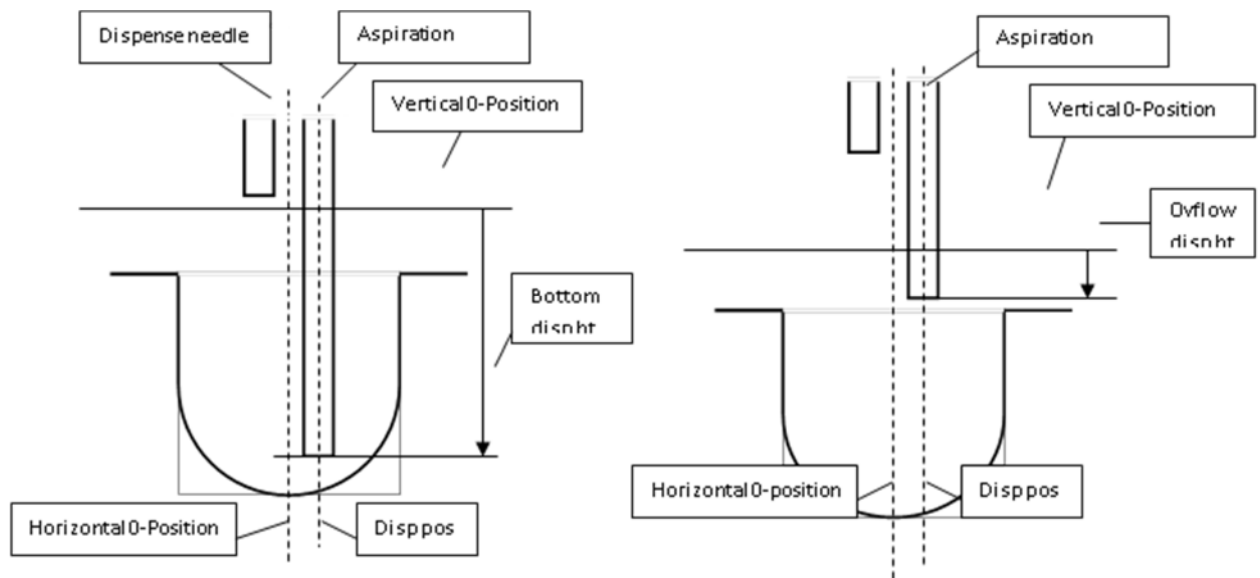

Drawing 50. Wash Positions for flat bottom and curved bottom plates

Def Plate:

<< >> <new>

Screen 51. Define Plate Menu

This menu defines all parameters for a plate. A defined plate is required to for a complete wash-procedure.

➤ **Function keys:**

<F1> or <F2>

Select another menu.

<+> or <->

Select "<new>" to define a new plate or select an existing plate to edit it.

<enter>

Confirm the selection of the plate and go to the next screen.

Name:

Esc Chg 1

Screen 52. Plate Name Entry

The name of the plate may be changed.

➤ **Function keys:**

<F1> or <F2>

Select "Esc" to return to main menu without saving any changes

Select "Chg" to change the name for the plate.

<enter>

Confirm the existing name and go to the next menu

Name:

Esc Sel A_

Screen 53. Plate Name Entry

➤ **Function keys:**

<F1> or <F2>

Select "Esc" to return to the main menu without saving any changes or "Sel" to select the current letter/number.

<+> or <->

Use these keys to scroll through the available letters (A-Z) and numbers (0-9)

<enter>

Confirm the name of the plate and go to the next screen.



Plate format:
<< Esc 8-strip

Screen 54. Plate Format Selection

➤ **Function keys:**

<F1> or <F2>

Select "Esc" to return to the main menu without saving any changes or "<<" to return to the previous screen.

<+> or <->

Use these keys to toggle between 8-strip, 12-strip and 16-strip plate.

<enter>

Confirm the selection of plate format and go to the next screen.

Well shape:
<< Esc Flat

Screen 55. Well Shape Selection

➤ **Function keys:**

<F1> or <F2>

Select "Esc" to return to the main menu without saving any changes or "<<" to return to the previous screen.

<+> or <->

Use these keys to toggle between flat- and round-bottom plates.

<enter>

Confirm the selection of well shape and go to the next screen.

Center pos:
Esc Mov 0.1 mm

Screen 56. Center Position Entry

This menu appears only if a round-bottom plate is selected. For round bottom plates it is recommended to position the aspiration needle in the center of the well. The center position may be defined by "teach-in" (move the plate to the correct position with the <+> and <-> keys).

Function keys:

<F1> or <F2>

Select "Esc" to return to the main menu without saving any changes.

Select "Mov" to position the plate to the current center position and switch to the "teach-in" mode.

<+> or <->

Use these keys to enter the center position. The plate can be moved in steps of 0.1mm (range: -5.0 – 5.0mm).

<enter>

Confirm the center position and go to the next screen.

Center pos: ↓ Mov 0.1 mm

Screen 57. Center Position "Teach-in" mode

In this 'teach-in' mode the round-bottom plate can be moved to the correct center position by using <+> or <->.

➤ Function keys:

<F1> or <F2>

Select "↓" to automatically detect the bottom of the well (changes to "↑").

Select "↑" to move the manifold up.

Select "Mov" to move the plate transport to the current center position.

<+> or <->

Use these keys to enter the center position. The plate can be moved in steps of 0.1mm (range: -5.0 – 5.0mm).

<enter>

Confirm the center position and go to the next screen.

Crosswise Aspir: << Esc Yes

Screen 58. Crosswise Aspiration Selection

If a flat-bottom plate is selected this menu appears. When using crosswise aspiration the aspiration needle is first moved close to one wall of the well (side pos front) and aspirates there. After the defined aspiration time the needle is moved up to avoid scratching the bottom and is shifted to the opposite wall (side pos rear). There the needle is moved down and another aspiration sequence takes place.

For a better aspiration result crosswise aspiration is advisable.
Crosswise aspiration can only be used for flat-bottom plates.

➤ **Function keys:**

<F1> or <F2>

Select "Esc" to return to the main menu without saving any changes or "<<" to return to the previous screen.

<+> or <->

Use these keys to toggle between "Yes" and "No".

<enter>

Confirm the selection for crosswise aspiration and go to the next screen.

```
Side pos front:
Esc  Mov  0.1 mm
```

Screen 59. Side Position Front Entry

In this menu the side position front for a flat-bottom plate is defined. If you choose crosswise aspiration this is the first aspiration position. Else this is the aspiration position: for a better aspiration result it is recommended to position the needle close to one wall. The side position front may be defined by "teach-in" (move the plate to the correct position with the <+> and <-> keys).

➤ **Function keys:**

<F1> or <F2>

Select "Esc" to return to the main menu without saving any changes.

Select "Mov" to position the plate to the current side position front and switch to the "teach-in" mode.<+> or <->

Use these keys to enter the side position front. The plate can be moved in steps of 0.1mm (range: -5.0 – 5.0mm).

<enter>

Confirm the side position front and go to the next screen.

```
Side pos front:
↓  Mov  0.1 mm
```

Screen 60. Side Position Front "Teach-in" mode

In this "teach-in" you can move the plate to the correct position with the <+> and <-> keys.

➤ **Function keys:**

<F1> or <F2>

Select "↓" to automatically detect the bottom of the well (changes to "↑").

Select "↑" to move the manifold up.

Select "Mov" to move the plate transport to the current side position front.

<+> or <->

Use these keys to enter the side position front. The plate can be moved in steps of 0.1mm (range: -5.0 – 5.0mm).

<enter>

Confirm the side position front and go to the next screen.

```
Side pos rear:
Esc  Mov  0.1 mm
```

Screen 61. Side Position Rear Entry

In this menu the side position rear for a flat-bottom plate is defined. It is only available if crosswise aspiration is enabled and it defines the second aspiration position. The side position rear may be defined by "teach-in" (move the plate to the correct position with the <+> and <-> keys).

➤ **Function keys:**

<F1> or <F2>

Select "Esc" to return to the main menu without saving any changes.

Select "Mov" to position the plate to the current side position rear and switch to the "teach-in" mode.

<+> or <->

Use these keys to enter the side position rear. The plate can be moved in steps of 0.1mm (range: -5.0 – 5.0mm).

<enter>

Confirm the side position rear and go to the next screen.

```
Side pos rear:
↓  Mov  0.1 mm
```

Screen 62. Side Position Rear "Teach-in" mode

In this "teach-in" mode the plate may be moved to the correct position with the <+> and <-> keys.

➤ **Function keys:**

<F1> or <F2>

Select "↓" to automatically detect the bottom of the well (changes to "↑").

Select "↑" to move the manifold up.

Select "Mov" to move the plate transport to the current side position rear.

<+> or <->

Use these keys to enter the side position rear. The plate can be moved in steps of 0.1mm (range: -5.0 – 5.0mm).

<enter>

Confirm the side position rear and go to the next screen.

Aspiration ht: Esc Mov 7.0 mm

Screen 63. Aspiration Height Position

The aspiration height position defines the height of the manifold during aspirating a well. It may be defined by "teach-in" (move the manifold to the correct position with the <+> and <-> keys).

➤ **Function keys:**

<F1> or <F2>

Select "Esc" to return to the main menu without saving any changes.

Select "Move" to position the manifold to the current aspiration height and switch to the "teach-in" mode.

<+> or <->

Use these keys to enter the aspiration height in steps of ~0.1mm (range: 0 – 18.8mm).

<enter>

Confirm the aspiration height and go to the next screen.

Aspiration ht: ↓ 0.1 mm

Screen 64. Aspiration Height "Teach-in" mode

In this special "teach-in" mode the manifold can be moved to the correct height with the <+> and <-> keys. This mode features automatic bottom detection. For an optimal aspiration, move the aspiration needle about 0.5mm up.

➤ **Function keys:**

<F1> or <F2>

Select "↓" to automatically detect the bottom of the well.

<+> or <->

Use these keys to move the manifold. The manifold can be moved in steps of ~0.1mm (range: 0 – 18.8mm).

<enter>

Confirm the aspiration height and go to the next screen.

Disp pos: Esc Mov 1.6 mm

Screen 65. Dispense Position

For washing the dispensing needle is placed above the well. From there it dispenses the washing solution into the well. The aspiration needle aspirates an overflow and prevents liquid spilling on next wells.

The dispense position defines the position of the plate below the manifold during washing. The dispensing needle should be above the well and the aspiration needle within. It may be defined by "teach-in" (move the plate to the correct position with the <+> and <-> keys).

➤ **Function keys:**

<F1> or <F2>

Select "Esc" to return to the main menu without saving any changes.

Select "Mov" to position the plate to the current dispense position and switch to the "teach-in" mode.

<+> or <->

Use these keys to enter the dispense position in steps of 0.1mm (range: -5.0 – 5.0mm).

<enter>

Confirm the dispense position and go to the next screen.



Disp pos:
↓ Mov 0.1 mm

Screen 66. Dispense Position "Teach-in" mode

In this "teach-in" mode the plate can be moved to the correct position with the <+> and <-> keys. With "Mov" and "↓" check if the needles are in correct position.

➤ **Function keys:**

- <F1> or <F2>
Select "↓" to automatically detect the bottom of the well (changes to "↑").
Select "↑" to move the manifold up.
Select "Mov" to move the plate transport to the current dispense position.
- <+> or <->
Use these keys to enter the dispense position. The plate can be moved in steps of 0.1mm (range: -5.0 – 5.0mm).
- <enter>
Confirm the dispense position and go to the next screen.

Bottom disp ht:
Esc Mov 0.0mm

Screen 67. Bottom Dispensing Position

For additional bottom washing the needles are moved upwards to Bottom dispensing height and then down again to the aspiration height.

The bottom dispensing height defines the vertical position of the manifold during dispensing of a bottom wash cycle. The dispensing height must be higher or equal the aspiration height. It may be defined by "teach-in" (move the manifold to the correct position with the <+> and <-> keys).

➤ **Function keys:**

- <F1> or <F2>
Select "Esc" to return to the main menu without saving any changes.
Select "Mov" to position the manifold to the current bottom dispense height and switch to the "teach-in" mode.

<+> or <->

Use these keys to enter the dispense height in steps of ~0.1mm (range: 0 – 18.8mm).

<enter>

Confirm the bottom dispensing position and go to the next screen.

Bottom disp ht: ↓ 0.1 mm
--

Screen 68. Bottom Dispense Height "Teach-in" mode

In this "teach-in" mode you can move the manifold to the correct height with the <+> and <-> keys.

➤ **Function keys:**

<F1> or <F2>

Select "↓" to automatically detect the bottom of the well.

<+> or <->

Use these keys to move the manifold. The manifold can be moved in steps of ~0.1mm (range: 0 – 18.8mm).

<enter>

Confirm the bottom dispense height and go to the next screen.

Ovflow disp ht: Esc Mov 4.0mm

Screen 69. Overflow Dispensing Height

It is recommended to use a dispense volume slightly higher than the well volume to produce an overflow phase. The slight flow rate variations among dispensing needles are compensated by the overflow phase.

The overflow dispensing height defines the height of the manifold for overflow washing. The position must be higher or equal as the aspiration height. It may be defined by "teach-in" (move the manifold to the correct position with the <+> and <-> keys).

➤ **Function keys:**

<F1> or <F2>

Select "Esc" to return to the main menu without saving any changes.

Select “Mov” to position the manifold to the current overflow dispense height and switch to the “teach-in” mode.

<+> or <->

Use these keys to enter the desired overflow dispense height in steps of ~0.1mm (range: 0 – 18.8mm).

<enter>

Confirm the overflow dispensing height and go to the next screen.

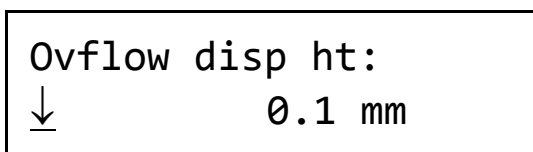

Screen 70.Overflow Dispense Height "Teach-in" mode

In this "teach-in" mode you can move the manifold to the correct height with the <+> and <-> keys.

➤ **Function keys:**

<F1> or <F2>

Select "↓" to automatically detect the bottom of the well.

<+> or <->

Use these keys to move the manifold. The manifold can be moved in steps of ~0.1mm (range: 0 – 18.8mm).

<enter>

Confirm the overflow dispense height. The set parameters will be stored and the program returns to the main menu.

9.6 Setup Menu

Please make sure to set all options according to your requirements.



Screen 71. Setup Menu

Use the <F1> / <F2> keys to select the setup menu. Confirm the selection with <enter>.



```
Language:
Esc      English
```

Screen 72. Language Setup

Use the <-> / <+> keys to select the language and confirm with <enter>.

```
Manifold:
<<  Esc    8needle
```

Screen 73. Manifold Setup

Use the <-> / <+> keys to select the manifold and confirm with <enter>.

```
Wash liquids:
<<  Esc    2
```

Screen 74. Liquids Setup

Use the <-> / <+> keys to select the number of wash liquids connected to your instrument and confirm with <enter>. Depending on the model of your instrument you can use up to 3 wash liquids.

```
Waste full det:
<<  Esc    Off
```

Screen 75. Waste Setup

Use the <-> / <+> keys to select whether a liquid level sensor is attached to the waste bottle and confirm with <enter>. To use this function a liquid level detector must be connected to the instrument and the waste bottle.

If activated the liquid level of the waste bottle will be checked before the procedure is started. In case that the level of the liquid in the waste bottle is above the sensor a corresponding warning will be displayed.



```
Rinse empty det:  
<< Esc Off
```

Screen 76. Rinse Setup

Use the <-> / <+> keys to select whether a liquid level sensor is attached to the rinse bottle and confirm with <enter>. To use this function a liquid level detector must be connected to the instrument and the rinse bottle.

If activated the liquid level of the rinse bottle for a started procedure will be checked before the procedure is started. In case that the level of the liquid in the rinse bottle is below the sensor a corresponding warning will be displayed.

```
Wash1 empty det:  
<< Esc Off
```

Screen 77. Wash1 Setup

Use the <-> / <+> keys to select whether a liquid level sensor is attached to the wash1 bottle and confirm with <enter>. To use this function a liquid level detector must be connected to the instrument and the wash1 bottle.

If activated the liquid level of the wash1 bottle for a started procedure will be checked before the procedure is started. In case that the level of the liquid in the wash1 bottle is below the sensor a corresponding warning will be displayed.

```
Wash2 empty det:  
<< Esc Off
```

Screen 78. Wash2 Setup

Use the <-> / <+> keys to select whether a liquid level sensor is attached to the wash2 bottle and confirm with <enter>. To use this function a liquid level detector must be connected to the instrument and the wash2 bottle.

If activated the liquid level of the wash2 bottle for a started procedure will be checked before the procedure is started. In case that the level of the liquid in the wash2 bottle is below the sensor a corresponding warning will be displayed.



```
Wash3 empty det:  
<< Esc      Off
```

Screen 79. Wash3 Setup

Use the <-> / <+> keys to select whether a liquid level sensor is attached to the wash3 bottle and confirm with <enter>. To use this function a liquid level detector must be connected to the instrument and the wash3 bottle.

If activated the liquid level of the wash3 bottle for a started procedure will be checked before the procedure is started. In case that the level of the liquid in the wash3 bottle is below the sensor a corresponding warning will be displayed.

```
Liquid warning:  
<< Esc      On
```

Screen 80. Liquid Warning Setup

Use the <-> / <+> keys to activate/deactivate the liquid warning and confirm with <enter>. If activated a reminder to check the level of the wash bottle(s) is displayed prior to the start of a procedure.

```
Waste warning:  
<< Esc      On Yes
```

Screen 81. Waste Warning Setup

Use the <-> / <+> keys to activate/deactivate the waste warning and confirm with <enter>. If activated a reminder to check the level of the waste bottle is displayed prior to the start of a procedure.

```
Plate warning:  
<< Esc      On Yes
```

Screen 82. Plate Warning Setup

Use the <-> / <+> keys to activate/deactivate the plate warning and confirm with <enter>.

```
Keyclick:
<<  Esc      On
```

Screen 83. Keyclick Setup

Use the <-> / <+> keys to activate/deactivate the keyclick and confirm with <enter>.

```
Emergency stop:?
<<  Esc      On
```

Screen 84. Emergency stop Setup

Use the <-> / <+> keys to activate/deactivate the emergency stop and confirm with <enter>

If a strip of a microplate or the microplate itself is not inserted correctly the tips of the manifold will hit the bottom. This triggers the bottom detection sensor and every process will be stopped immediately.

9.7 Service Menu

```
Service
<<  >>  Sensors
```

Screen 85. Service Menu

This menu checks various functions of the instrument. It is only intended to be used by trained service personnel.

10 ERROR MESSAGES

10.1.1 Duplicate Name

Duplicate name
Press any key

Screen 86. Duplicate Name

The name for the procedure, cycle or plate is already used

➤ **Function keys:**

<enter>

Confirm the message.

10.1.2 Wrong Manifold

Wrong manifold
Press any key

Screen 87. Wrong Manifold

The wrong manifold for the selected procedure is installed.

➤ **Function keys:**

<enter>

Confirm the message.

10.1.3 No Cycle Defined

No cycle defined
Press any key

Screen 88. No Cycle Defined

There is no cycle defined.

➤ **Function keys:**

<enter>

Confirm the message.

10.1.4 No Plate Defined

No plate defined
Press any key

Screen 89. No Plate Defined

There is no plate defined.

➤ **Function keys:**

<enter>

Confirm the message.

10.1.5 Waste Full

Waste full
Press any key

Screen 90. Waste Full

The waste is full. Empty the waste bottle.

➤ **Function keys:**

<enter>

Confirm the message.

10.1.6 Liquid Empty

Liquid empty
Press any key

Screen 91. Liquid Empty

The selected wash liquid is empty.

➤ **Function keys:**

<enter>

Confirm the message.

10.1.7 Stop Pressed

Stop pressed
Press any key

Screen 92. Stop Pressed

The user has stopped the instrument.

➤ **Function keys:**

<enter>

Confirm the message.

10.1.8 Plate Transport Error

Platetrans error
Press any key

Screen 93. Plate Transport Error

The plate transport failed.

➤ **Function keys:**

<enter>

Confirm the message.

10.1.9 Manifold Transport Error

MF-trans error
Press any key

Screen 94. Manifold Transport Error

The manifold transport failed.

➤ **Function keys:**

<enter>

Confirm the message.

11 Maintenance

11.1 Recommended regular inspection

The Atlantis is designed in a way that during appropriate use no danger for the user is caused.

Correct functional performance is assured by an automatic check of the relevant technical parameters during operation. In case of a problem the instrument reports an error message.

Biochrom recommends that an instrument should be inspected by an authorized service partner at an interval of about 2 years. During this inspection the correct function of the instrument can be verified.

11.2 Approved parts

Except for the parts shown in the following list only parts supplied by Biochrom or an authorized Biochrom Distributor may be installed in or used with ASYS Atlantis:

Fuses: as specified in chapter

4.1.1 Rated operating conditions

Power cable: CE-marked power cable with connected protective earth and protective earth connector
(see also **4.8 Installation requirements, Environmental operating conditions**)

External Computer controlling the instrument
(see also Error! Reference source not found. Error! Reference source not found.)

11.3 Exchanging a Fuse

In case of malfunction (the green stand-by indicator is not illuminated), the fuses located in the mains inlet next to the mains socket on the rear side of the device can be checked and replaced if necessary.

- Disconnect the instrument from mains by unplugging the power cable.
- Open fuse-carrier next to the mains socket with a screwdriver
- Remove fuse

- Insert spare included in supply (2 pcs. 2.5 A TH250VAC,
- Close fuse-carrier.
- Turn device on and check function. In case of malfunction, call a service technician.

11.4 Cleaning the instrument

This instrument is a precision instrument and requires regular cleaning to ensure the continued high performance.

- **Liquid spillage**

If any liquid is spilled on the instrument, it should be IMMEDIATELY removed so that the liquid does not attack the surface of the housing.

- **Regular cleaning**

The housing of the instrument should be cleaned regularly with a mild household cleaning agent.

Warning: Do not use aggressive solutions!

The area surrounding the plate carrier should be cleaned with a dry cloth.

- **Fittings and tubing**

The usual wash buffer tends to crystallize easily on air and can block tubing and fittings then. Use the automatic rinse program daily and do not leave the tubing filled with wash buffer for an extended period of time.

11.5 Disinfection Procedure

If the laboratory has no specific disinfection procedure, the following procedure should be used to disinfect the instrument.

The instrument should be disinfected using a suitable disinfection solution.

1. Disconnect the instrument from the mains power supply.
2. Carefully wipe all the outside surfaces of the instrument and the plate area with a wad of cotton wool that has been soaked in the disinfection solution.

Note: Ensure that disposable gloves are worn.

- 3 Place the instrument in to a large plastic bag.

- 
4. Place a wad of cotton wool that has been soaked in the disinfection solution in to the plastic bag.

Note: Ensure that the wad is not touching the instrument.

5. Close and seal the plastic bag.
6. Leave the instrument to stand in the plastic bag for at least 24 hours.
7. After the standing time, remove the instrument from the plastic bag and wipe all the outside surfaces of the instrument and the plate support area with a wad of cotton wool which has been soaked in a 50% Alcohol solution.
8. Repeat the disinfection procedure on any accessories which are also being moved or returned.

The pumps can be disinfected by dispensing and aspirating a sufficient amount of disinfectant fluid. After the disinfection procedure dispense > 200 ml of distilled water to remove all disinfectant fluid from the liquid carrying parts.



12 Intended Use

This device is intended for research use only. It is not for clinical use on patients. It is to be used to remove non-bound sample-sera or to remove reagents from 96-well respectively 384-well microplates or format-identical strips. By means of repeated liquid exchange down to a defined minimum rest volume, for which the sample-/reagent-liquid is aspirated from the wells into a "waste"-bottle and the wash liquid is dispensed from stock-("wash-")bottles into the wells of the microplate, the concentration of the sample shall be diluted until no diagnostically-relevant rest remains.

The main field of use is ELISA-testing operated and carried out by trained specialist staff (medical and/or laboratory).

12.1 Quality control

The quality control criteria of a diagnostic kit have to be described in the package insert of the kit. For the performance of any reagent quality control it has to be referred exclusively to those instructions.

It is the user's responsibility to ensure proper operation according to the instructions given with each individual test.